



Optional Weather Resistant
Housing & Bracket
(Model: XIP3000H)

Model: **XIP3101**
Wireless IP Camera with IR Night
Vision & 3G Mobile Phone Access

Before you begin

- Please unpack the box carefully and identify that all the parts are present.

The camera is suitable for indoor or outdoor use (using optional housing). Please bear in mind the following points when choosing a mounting position.

- The camera must be positioned so that it will not point directly into the sun (sunrise and sunset) or any bright light, as this may cause damage to the camera.
- Avoid viewing areas where half the area is in bright sunlight and the other half is dark, such as in the shadow of a building. All types of cameras have difficulty in 'seeing' with such a large lux level variation.
- Do not cut the camera cables, this will void the warranty.
- Make sure you use only the recommended power supply. Damage caused to the camera by incorrect voltage or wiring is not covered by the warranty.

Model:
XIP3101

Wireless IP Camera with IR Night
Vision & 3G Mobile Phone Access

Advanced Installation Guide

PREFACE

Thank you for purchasing the XIP3101 Wireless IP CCTV Camera, a powerful IP CCTV camera with 2-way audio function that provides high-quality images and audio via an Internet connection. The Infrared LEDs and light sensor enable the camera to capture images even in a dark environment. The camera can be installed as a standalone system within your application environment easily and quickly, and supports remote management function so that you can access and control it using a Web browser on your PC.

This *Advanced Installation Guide* provides you with the instructions and illustrations on how to use your camera, which includes:

- Chapter 1** **Introduction to Your Camera** describes the features of the camera. You will also know the components and functions of the camera.
- Chapter 2** **Hardware Installation** helps you install the camera according to your application environment. You can use this camera at home, at work, at any where you want.
- Chapter 3** **Accessing the Camera** lets you start using your camera without problem. The camera can be set up easily and work within your network environment instantly.
- Chapter 4** **Configuring the Camera** guides you through the configuration of the camera using the web browser on your PC.
- Chapter 5** **Appendix** provides the specification of the camera and some useful information for using your camera.

NOTE The illustrations and configuration values in this guide are for reference only. The actual settings depend on your practical application of the camera.

Contents

Preface	1
Chapter 1 Introduction To Your Camera	3
1.1 Checking the Package Contents	3
1.2 Getting to Know Your Camera	4
1.3 Features and Benefits	6
1.4 System Requirement	8
Chapter 2 Hardware Installation	9
2.1 Installing the Camera Stand	9
2.2 Connecting the Camera to LAN/WLAN.....	10
2.3 Applications of the Camera.....	11
Chapter 3 Accessing the Camera	12
3.1 Using IPFinder.....	12
3.2 Accessing to the Camera.....	13
3.3 Configuring the IP Address of the PC.....	16
Chapter 4 Configuring the Camera	17
4.1 Using the Web Configuration.....	17
4.2 Using Smart Wizard	18
4.3 Basic Setup.....	21
4.4 Network Settings	23
4.5 Setting up Video & Audio	29
4.6 Event Server Configuration	34
4.7 Motion Detect.....	37
4.8 Event Config	38
4.9 Tools.....	41
4.10 USB.....	43
4.11 Information	45
Chapter 5 Appendix.....	46
A.1 Specification	46
A.2 Glossary of Terms.....	48

CHAPTER 1

INTRODUCTION TO YOUR CAMERA

1.1 Checking the Package Contents

Check the items contained in the package carefully. You should have the following:

- One Wireless IP CCTV Camera.
- One AC Power Adapter.
- One External Antenna.
- One Camera Bracket.
- One Ethernet Cable (RJ-45 type).
- One Installation CD-ROM.
- One Quick Installation Guide.

NOTE Once any item contained is damaged or missing, contact your local distributor.

1.2 Getting to know your Camera

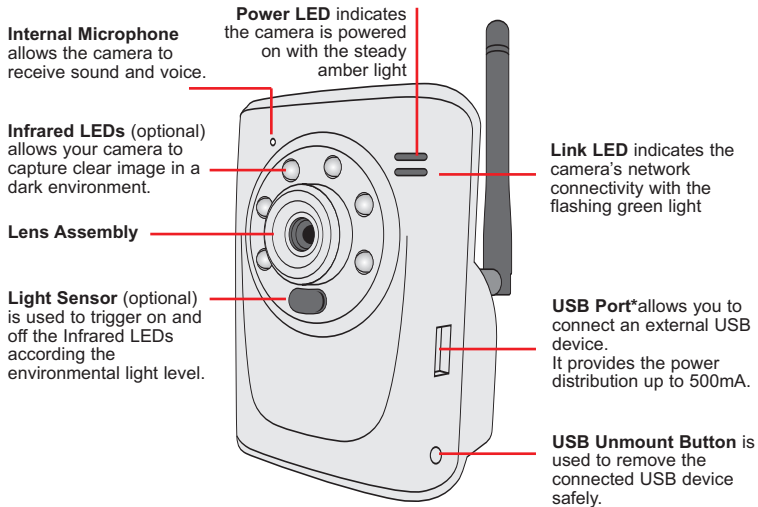

Front View

* The camera's USB port supports WCN (Windows Connect Now) technology, which allows you to use the notebook computer to set up and store your wireless networking configuration on the USB storage device, and then retrieve the wireless settings when you connect the USB storage device to the camera.

NOTE After pressing the Unmount button for four seconds, the Power LED starts flashing. When the Power LED resumes the steady amber light, you can remove the USB device safely.

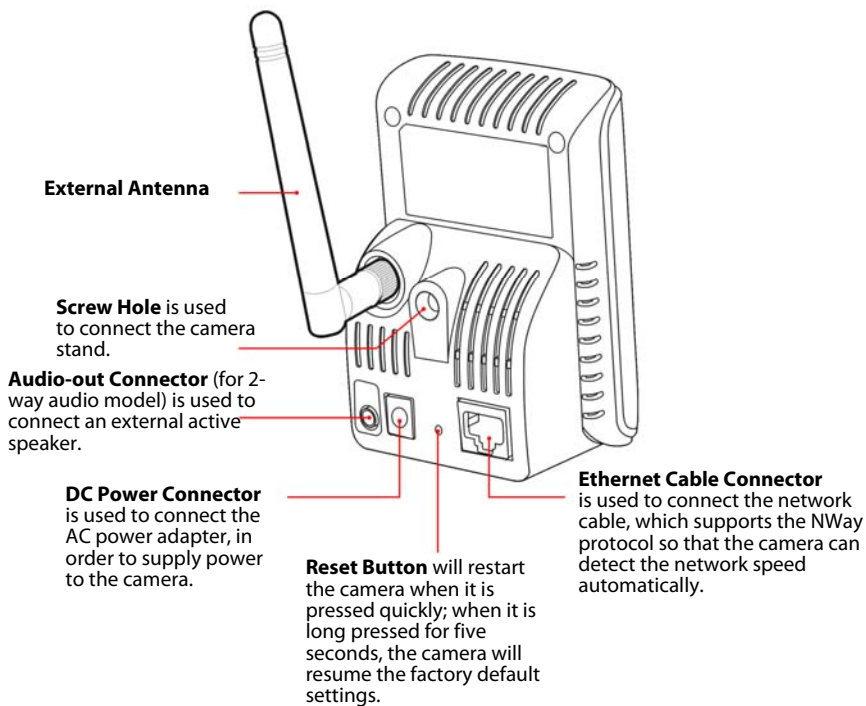

Rear View

1.3 Features and Benefits

■ MPEG4/MJPEG/RTSP Supported

The camera provides you with excellent images by the MPEG4/MJPEG/RTSP triple codec selectable technology, allowing you to adjust image size and quality, and bit rate accordingly to the networking environment.

■ Audio Capability

The built-in microphone of the camera provides on-the-spot audio via the Internet, allowing you to monitor the on-site voice. In addition, you can connect an external speaker to the camera to speak through the camera; the camera is embedded with echo cancellation processor to provide a better sound quality.

■ Day & Night Surveillance Supported

The six Infrared LEDs around the lens enable the camera to capture crystal clear images in a dark environment or at night. When the Light Sensor detects the environmental light level dropping, the camera captures the images in black & white mode and turns on the infrared LEDs.

■ Supports Triple Streaming Profiles

The camera supports multiple profiles simultaneously, so that you can separately set up different image settings (such as image quality and frame rate) for MJPEG, MPEG4 and 3GPP.

■ Supports RTSP

The camera supports RTSP (Real Time Streaming Protocol), which is a technology that allows you to view streaming media via the network. You can view the real-time video with the Quick Time player or RealPlayer. To view the real time streaming image on your computer, open the Web browser and enter the RTSP link: [rtsp://\(IP address of the camera\)/mpeg4](rtsp://(IP address of the camera)/mpeg4).

■ **Remote Control Supported**

By using a standard Web browser or the bundled Xview Recording & Viewing Software software application, the administrator can easily change the configuration of the camera via Intranet or Internet. In addition, the camera can be upgraded remotely when a new firmware is available. The users are also allowed to monitor the image and take snapshots via the network.

■ **Supports Connection to the External Devices**

With the auxiliary Input/Output connectors, you can connect the camera to a variety of external devices, such as the external speaker and the USB device.

■ **Multiple Platforms Supported**

The camera supports multiple network protocols, including TCP/IP, SMTP e-mail, HTTP, and other Internet related protocols. Therefore, you can use the camera in a mixed operating system environment, such as Windows 2000 and Windows XP.

■ **Multiple Applications Supported**

Through the remote access technology, you can use the cameras to monitor various objects and places for your own purposes. For example, babies at home, patients in the hospital, offices and banks, and more. The camera can capture both still images and video clips, so that you can keep the archives and restore them at any time.

■ **3G Mobile Phone/PDA Support**

The camera can be viewed live using any compatible 3G Mobile Phone or PDA that supports 3GPP, Real Player or Quick Time.

1.4 System Requirement

■ Networking

LAN: 10Base-T Ethernet or 100Base-TX Fast Ethernet.

WLAN: IEEE 802.11b/g (Model XIP3001 only).

■ Configuring the Camera:

CPU: Pentium 3, 350MHz or above

Memory Size: 128MB or above

Resolution: 800 x 600 or above

Browser: Internet Explorer 6.0 or above

Operating Systems: Windows 2000/XP/Vista

■ Viewing the Camera:

CPU: Pentium 3, 350MHz or above

Memory Size: 128MB or above

Resolution: 800 x 600 or above

Browser: Internet Explorer 6.0 or above, Apple Safari 2.0 or Mozilla Firefox

Operating Systems: Windows 2000/XP/Vista, Apple OSX

*Please note audio is not available when using Safari or Firefox

■ Accessing the camera using Xview Recording & Viewing Software

1 camera connected:

CPU: Pentium 3, 800MHz

Memory Size: 512MB

5 to 8 cameras connected:

CPU: Pentium 4, 2.4GHz

Memory Size: 1.0GB

2 to 4 cameras connected:

CPU: Pentium 3, 1.3GHz

Memory Size: 512MB

9 to 16 cameras connected:

CPU: Pentium 4, 3.2GHz

Memory Size: 1.0GB

Resolution: 1024 x 768 or above

Operating Systems: Windows 2000/XP/Vista

NOTE If you connect multiple cameras to monitor various places simultaneously, you are recommended to use a computer with higher performance.

CHAPTER 2

HARDWARE INSTALLATION

2.1 Installing the Camera Stand

The camera comes with a camera stand, which uses a swivel ball screw head to lock to the camera's screw hole. When the camera stand is attached, you can place the camera anywhere by mounting the camera through the three screw holes located in the base of the camera stand.

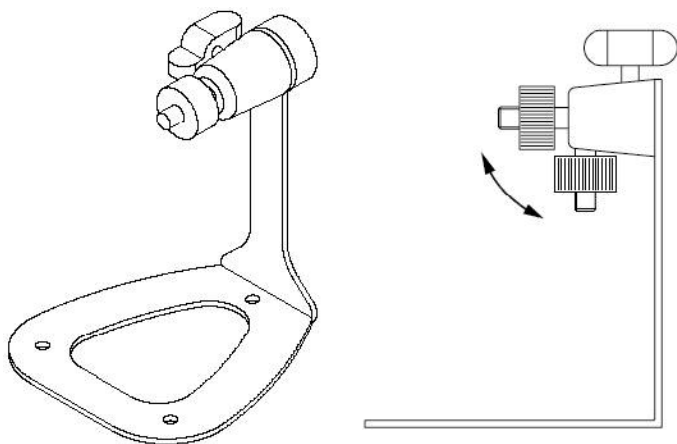

2.2 Connecting the Camera to LAN/WLAN

Use the provided Ethernet cable to connect the camera to your local area network (LAN).

When you connect the AC power adapter, the camera is powered on automatically. You can verify the power status from the Power LED on the front panel of the camera.

Once connected, the Link LED starts flashing green light and the camera is on standby and ready for use now.

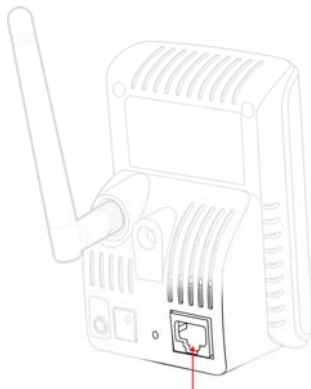

Connecting the Ethernet Cable

If you use a wireless network in your application environment, you need to attach the included external antenna to the camera.

When the camera is powered on, the camera will automatically search any access point with "default" SSID.

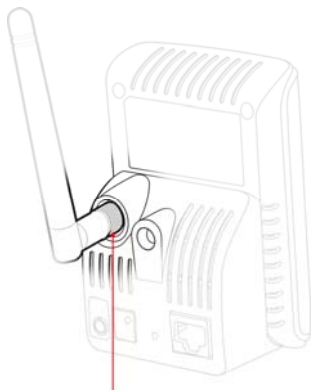

Connecting the External Antenna

NOTE If the camera cannot to your wireless network, you need to install the camera in LAN and proceed with WLAN settings.

2.3 Applications of the Camera

The camera can be applied in multiple applications, including:

- Monitor local and remote places and objects via Internet or Intranet.
- Capture still images and video clips remotely.
- Upload images or send email messages with the still images attached.

The following diagram explains one of the typical applications for your camera and provides a basic example for installing the camera.

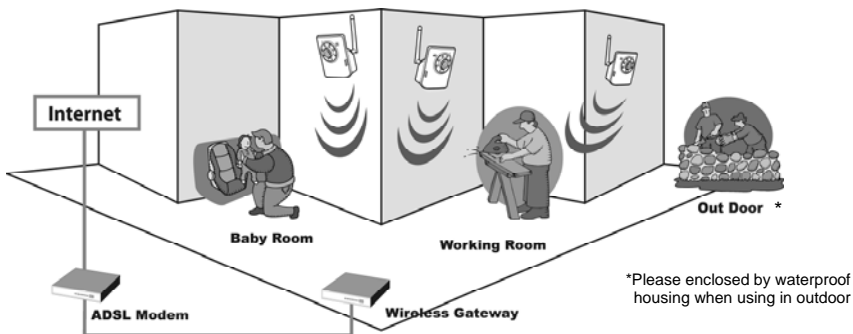

Home Applications

CHAPTER 3

ACCESSING THE CAMERA

3.1 Using IPFinder

The camera comes with a conveniently utility, IPFinder, which is included in the Installation CD-ROM, allowing you to search the camera on your network easily.

1. Insert the Installation CD-ROM into your computer's CD-ROM drive to initiate the Auto-Run program.
2. Click the IPFinder item to launch the utility. The control panel will appear as below.

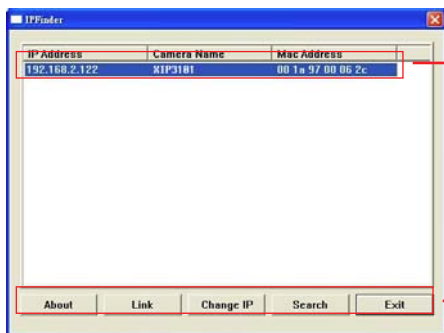

Display the connected camera(s)
Double click to link the camera

Click **About** to get the Version information of IPFinder.
Click **Link** to connect the selected camera.
Click **Search** to find the IP address of the connected camera(s).
Click **Change IP** to modify the IP address of the selected camera.
Click **Exit** to close the utility.

3. Once you get the IP address of the camera, launch the Web browser or Xview Recording & Viewing Software to access your camera.

3.2 Accessing to the Camera

Whenever you want to access the camera:

1. Open the Web browser on your computer (for example, Microsoft Internet Explorer in this guide)
2. Type the default IP address (**192.168.0.30**) or the IP address found by IPFinder in the Address bar, and then press [Enter].
3. When the login window appears, enter the default User name (**admin**) and password (**admin**) and press **OK** to access to the main screen of the camera's Web Configuration.

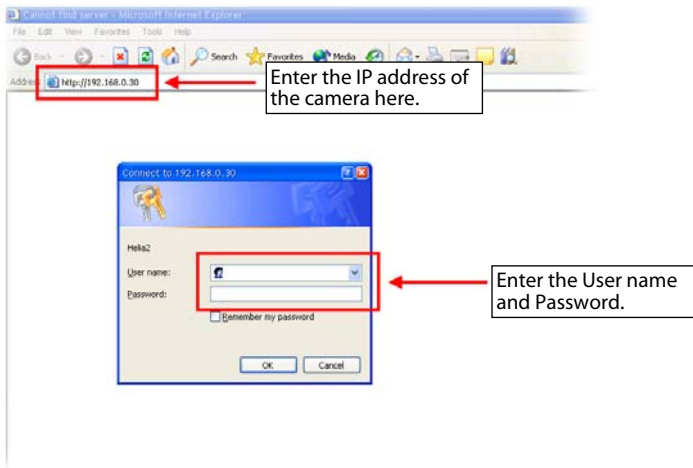

NOTE If you are initially access to the camera, you will be ask to install a new plug-in for the camera. Permission request depends on the Internet security settings of your computer. Click **Yes** to proceed.

After you login into the Web Configuration of the camera, the main page will appear as below:

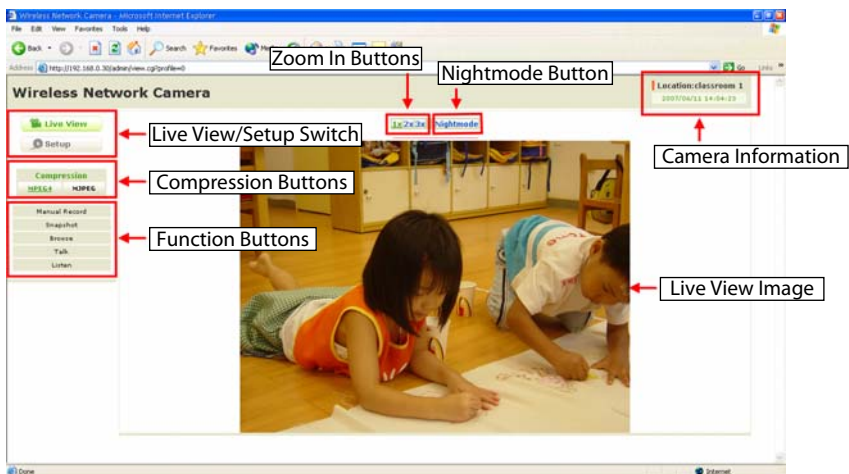

The main page of the Web Configuration provides you with many useful information and functions, including:

- **Camera Information** – Display the camera’s location and the current date & time. The information can be modified in the Web Configuration.
- **Live View Image** – Displays the real-time image of the connected camera.
- **Live View/Setup Switch** – Click **Setup** to configure the camera. For details, see Chapter 4.
- **Compression Buttons** – Select to transmit and record the video using MPEG4 or MJPEG compression.

- **Function Buttons** – Use these buttons to control the audio and video functions.
 - **Manual Record** allows you to record and save a video clip.
 - **Snapshot** allows you to capture and save a still image.
 - **Browse** allows assign the destination folder to store the video clips and still images.
 - **Talk** allows you to speak out through the camera. Please note that this button displays only for the 2-way audio model, and only one user is allowed to use this function at a time.
 - **Listen** allows you receive the on-site sound and voice from the camera.
- **Zoom In Buttons** – Click the buttons to zoom in the live view image by 1x, 2x, and 3x.
- **Nightmode Button** – Click the button to enable the “nightshot mode” to deliver clearer images in the dark environment. However, this will reduce the frame rate of video setting.

NOTE If your PC use Microsoft Vista platform. Maybe you can't find these recorded files what stored by **Snapshot** or **Manual Record**. That you need to disable the protected mode of Security in the IE Browser. Please follow as below Steps:

1. Open IE Browser
2. Select **Tools**→**Internet Options**
3. Select **Security**
4. Disable the “**Enable Protected Mode**” then press **OK**

3.3 Configuring the IP Address of the PC

If you are failed to access to the camera, please check the IP address of your computer. When you connect the camera to your computer directly to proceed with configuration of the camera, you need to set up the IP addresses to be in the same segment for the two devices to communicate.

1. On your computer, click **Start > Control Panel** to open the Control Panel window.
2. Double-click **Network Connection** to open the Network Connection window.
3. Right-click **Local Area Connection** and then click **Properties** from the shortcut menu.
4. When the Local Area Connection Properties window appears, select the **General** tab.
5. Select **Internet Protocol [TCP/IP]** and then click **Properties** to bring up the Internet Protocol [TCP/IP] Properties window.
6. To configure a fixed IP address that is within the segment of the camera, select the **Use the following IP address** option. Then, enter an IP address into the empty field. The suggested IP address is **192.168.0.x** (x is 1~254 except 30), and the suggested Subnet mask is **255.255.255.0**.
7. When you are finished, click **OK**.

CHAPTER 4

CONFIGURING THE CAMERA

4.1 Using the Web Configuration

You can access and manage the camera through the Web browser and the provided software application Xview Recording & Viewing Software. This chapter describes the Web Configuration, and guides you through the configuration of the camera by using the web browser.

To configure the camera, click **Setup** on the main page of Web Configuration. The Web Configuration will start from the **Basic** page.

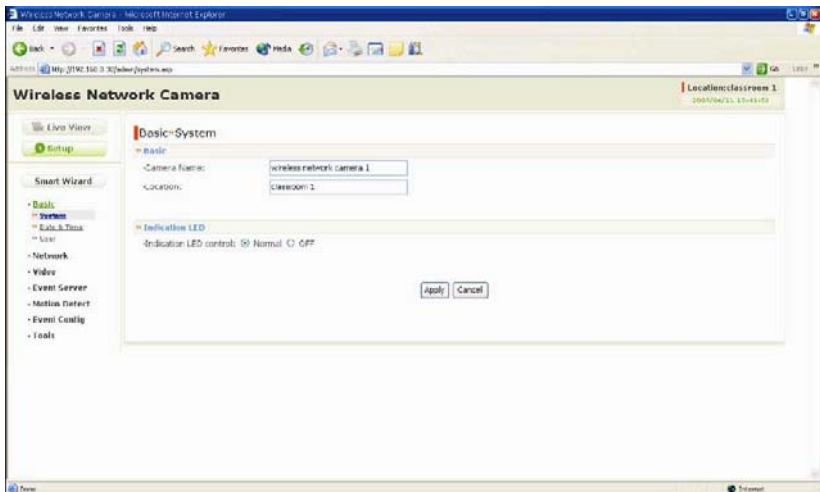

The Web Configuration contains the settings that are required for the camera in the left menu bar, including **Smart Wizard, Basic, Network, Video, Event Server, Motion detect, Event Config, Tools, and Information.**

4.2 Using Smart Wizard

The camera's Smart Wizard lets you configure your camera easily and quickly. The wizard will guide you through the necessary settings with detailed instructions on each step.

To start the wizard, click **Smart Wizard** in the left menu bar.

Step 1. Camera Settings

Camera Settings

• Camera Name: ← Enter the name for the camera and place.

• Location:

• Admin Password: ← Enter the administrator password.

• Confirm Password:

Step 2. IP Settings

IP Settings

• DHCP

• Static IP

• PPPoE

• IP: . . .

• Subnet Mask: . . .

• Default Gateway: . . .

• Primary DNS: . . .

• Secondary DNS: . . .

• User Name:

• Password:

Select the IP setting according to your network: **DHCP**, **Static IP**, or **PPPoE**.

Step 3. Email Settings

Email Settings

-SMTP Server Address:

-Sender Email Address:

-Authentication Mode: None SMTP

-Sender User Name:

-Sender Password:

-Receiver #1 Email Address:

-Receiver #2 Email Address:

< Prev Next > Cancel

Enter the required information to be able to send email with image.

Step 4. Wireless Networking

Wireless Networking

Enable

-Network ID(SSID):

-Wireless Mode: Infrastructure Ad-Hoc

-Channel:

-Authentication:

• Encryption None WEP

• Format ASCII HEX

• Key Length 64 bits 128 bits

WEP Key 1

WEP Key 2

WEP Key 3

WEP Key 4

< Prev Next > Cancel

Select **Enable** to enable the wireless function of the camera, and then complete the required settings.

Step 5. Confirm Settings

Confirm Settings

-Camera Name:	wireless network camera 1
-Location:	classroom 1
-IP Mode:	DHCP
-IP Address:	192.168.0.30
-Subnet Mask:	255.255.255.0
-Default Gateway:	192.168.0.1
-MAC Address:	00:FF:00:05:21:01
-Primary DNS Address:	
-Secondary DNS Address:	
-SMTP Server Address:	
-Sender Email Address:	
-Authentication mode:	None
-Sender User Name:	
-Receiver #1 Email Address:	
-Receiver #2 Email Address:	
-Connection:	Infrastructure
-Channel:	6
-Authentication :	Open
-Encryption :	None

This step shows the configuration of your camera. When you confirm the settings, click **Apply** to finish the wizard and reboot the camera. Otherwise, click **Prev** to go back to the previous step(s) and change the settings; or click **Cancel** to end the wizard and discard the changes.

4.3 Basic Setup

The Basic menu contains three sub-menus that provide the system settings for the camera, such as the Camera Name, Location, Date & Time, and User management.

Basic >> System

■ Basic

- **Camera Name:** Enter a descriptive name for the camera.
- **Location:** Enter a descriptive name for the location used by the camera.

■ Indication LED

This item allows you to set the LED illumination as desired. There are two options: **Normal** and **OFF**.

Basic >> Date & Time

■ Date & Time

- **TimeZone:** Select the proper time zone for the region from the pull-down menu.
- **Synchronize with PC:** Select this option and the date & time settings of the camera will be synchronized with the connected computer.
- **Synchronize with NTP Server:** Select this option and the time will be synchronized with the NTP Server. You need to enter the IP address of the server and select the update interval in the following two boxes.

- **Manual:** Select this option to set the date and time manually.

Basic >> User

■ Administrator

To prevent unauthorized access to the camera's Web Configuration, you are strongly recommend to change the default administrator password. Type the administrator password twice to set and confirm the password.

■ General User

- **User Name:** Enter the user's name you want to add to use the camera.
- **Password:** Enter the password for the new user.

When you are finished, click **Add/Modify** to add the new user to the camera. To modify the user's information, select the one you want to modify from **UserList** and click **Add/Modify**.

- **UserList:** Display the existing users of the camera. To delete a user, select the one you want to delete and click **Delete**.

■ Guest

- **User Name:** Enter the guest's name you want to add to use the camera.
- **Password:** Enter the password for the new guest.
- **UserList:** Display the existing guests of the camera. To delete a user, select the one you want to delete and click **Delete**.

NOTE The "General User" can access the camera and control the Function buttons of the camera's Web Configuration; the "Guest" can only view the live view image from the main page of the Web Configuration while accessing the camera. Only the "Administrator" is allowed to configure the camera through the Web Configuration.

4.4 Network Settings

The Network menu contains three sub-menus that provide the network settings for the camera, such as the IP Setting, DDNS Setting, IP Filter, and Wireless network.

The screenshot shows a web browser window titled "Wireless Network Camera - Microsoft Internet Explorer". The address bar shows "http://192.168.0.30/admin/network.asp". The page content is titled "Wireless Network Camera" and features a navigation sidebar on the left with options like "Live View", "Setup", "Smart Wizard", and "Basic". The main content area is titled "Network > Network" and contains several sections:

- IP setting**: Includes radio buttons for DHCP (selected) and Static IP. Under Static IP, there are input fields for IP (192, 168, 0, 30), Subnet Mask (255, 255, 255, 0), Default Gateway (192, 168, 0, 1), Primary DNS, and Secondary DNS.
- PPPoE**: Includes radio buttons for PPPoE (not selected) and fields for User Name and Password.
- DDNS Setting**: Includes a checkbox for "Enable" (unchecked), a dropdown for "Provider" (members.dyndns.org), and fields for Host Name, User Name, and Password.
- UPnP**: Includes a checkbox for "Enable" (checked).
- Ports Number**: Includes input fields for HTTP Port (80, default: 80) and RTSP Port (554, default: 554).

At the bottom right of the settings area, there are "Apply" and "Cancel" buttons. The browser's address bar at the bottom shows "http://192.168.0.30/admin/wireless.asp".

Network >> Network

■ IP Setting

This item allows you to select the IP address mode and set up the related configuration.

- **DHCP:** Select this option when your network uses the DHCP server. When the camera starts up, it will be assigned an IP address from the DHCP server automatically.
- **Static IP:** Select this option to assign the IP address for the camera directly. You can use IPFinder to obtain the related setting values.

IP	Enter the IP address of the camera. The default setting is 192.168.0.30 .
Subnet Mask	Enter the Subnet Mask of the camera. The default setting is 255.255.255.0 .
Default Gateway	Enter the Default Gateway of the camera. The default setting is 192.168.0.1 .
Primary/ Secondary DNS	DNS (Domain Name System) translates domain names into IP addresses. Enter the Primary DNS and Secondary DNS that are provided by ISP.

- **PPPoE:** Select this option when you use a direct connection via the ADSL modem. You should have a PPPoE account from your Internet service provider. Enter the **User Name** and **Password**. The camera will get an IP address from the ISP as starting up.

NOTE Once the camera get an IP address from the ISP as starting up, it automatically sends a notification email to you. Therefore, when you select PPPoE as your connecting type, you have to set up the email or DDNS configuration in advance.

DDNS Setting

With the Dynamic DNS feature, you can assign a fixed host and domain name to a dynamic Internet IP address. Select the **Enable** option to enable this feature. Then, select the Provider from the pull-down list and enter the required information in the **Host Name**, **User Name**, and **Password** boxes. Please note that you have to sign up for DDNS service with the service provider first.

■ UPnP

The camera supports UPnP (Universal Plug and Play), which is a set of computer network protocols that enable the device-to-device interoperability. In addition, it supports port auto mapping function so that you can access the camera if it is behind an NAT router or firewall. Select the **Enable** option to enable this feature.

■ Ports Number

- **HTTP Port:** The default HTTP port is **80**.
- **RTSP Port:** Configure the transmission of streaming data within the network. The default RTSP (Real Time Streaming Protocol) port is **554**.

NOTE If the camera is behind an NAT router or firewall, the suggested to be used is from 1024 to 65535.

Network >> IP Filter

The IP Filter setting allows the administrator of the camera to limit the users within a certain range of IP addresses to access the camera.

■ Start/End IP Address

Assign a range of IP addresses that are not allowed to access the camera by entering the Start IP address and End IP address.

When you are finished, click Add to save the range setting. You can repeat the action to assign multiple ranges for the camera.

For example, when you enter 192.168.0.50 in Start IP Address and 192.168.0.80 in End IP Address, the user whose IP address located within 192.168.0.50 ~ 192.168.0.80 will not be allowed to access the camera.

■ Deny IP List

The list displays the range setting(s) of IP addresses that are not allowed to access the camera. To clear the setting, select a range of IP addresses from the list and click **Delete**.

Network>>Wireless

■ Wireless

The camera supports WLAN while you use the wireless network. Select the **Enable** option to enable this feature.

-Network ID (SSID): Keep the default setting of this option to connect the camera to any access point under the infrastructure network mode. To connect the camera to a specified access point, set a SSID for the camera to correspond with the access point's ESS-ID. To connect the camera to an Ad-Hoc wireless workgroup, set the same wireless channel and SSID to match with the computer's configuration.

Click **Site Survey** to display the available wireless networks, so that you can easily connect to one of the listed wireless networks.

Network » Wireless Setting

» Wireless

Enable

Network ID(SSID):

ESSID	Mac	Channel	Mod
corega	00:0a:79:aa:a3:7f	2	Infra
Jasmine	00:18:f3:64:4d:61	2	Infra
DI-724P	00:50:18:38:41:aa	6	Infra
asus-wl520g	00:18:f3:64:4d:27	10	Infra
allen	00:19:cb:0a:bc:61	11	Infra

List of searching results

- **Wireless Mode:** Select the type of wireless communication for the camera: Infrastructure or Ad-Hoc.
- **Channel:** Select the appropriate channel from the list.
- **Authentication:** Select the authentication method to secure the camera from being used by unauthorized user: Open, Shared-key, WPA-PSK, and WPA2-PSK. The following table explains the four options:

Open	The default setting of Authentication mode, which communicates the key across the network.
Shared-key	Allow communication only with other devices with identical WEP settings.
WPA-PSK/ WPA2-PSK	WPA-PSK/WPA2-PSK is specially designed for the users who do not have access to network authentication servers. The user has to manually enter the starting password in their access point or gateway, as well as in each PC on the wireless network.

If you select **Open** or **Shared-key** as the Authentication mode, you need to complete the following settings:

Encryption: Select the **WEP** option to enable the data encryption feature to secure the camera within the wireless network.

Format: Once you enable the Encryption feature, you need to determine the encryption format by selecting **ASCII** or **HEX**. ASCII format causes each character you type to be interpreted as an eight-bit value. Hex format causes each pair of characters you type to be interpreted as an eight-bit value in hexadecimal (base 16) notation.

Key Length: Select the WEP key length you use: **64 bits** or **128 bits**.

WEP Key 1/2/3/4: Enter the WEP key(s) in the following boxes.

If you select **WPA-PSK** or **WPA2-PSK** as the Authentication mode, you need to complete the following settings:

Encryption: Select **TKIP** or **AES**. TKIP (Temporal Key Integrity Protocol) changes the temporal key every 10,000 packets to insure much greater security than the standard WEP security. AES (Advanced Encryption Standard) is used to ensure the highest degree of security and authenticity for digital information.

Pre-Shared Key: This is used to identify each other in the network. Enter the name in the box, and this name must match the Pre-shared key value in the remote device.

4.5 Setting up Video & Audio

The Video & Audio menu contains three sub-menus that provide the video and audio settings for the camera.

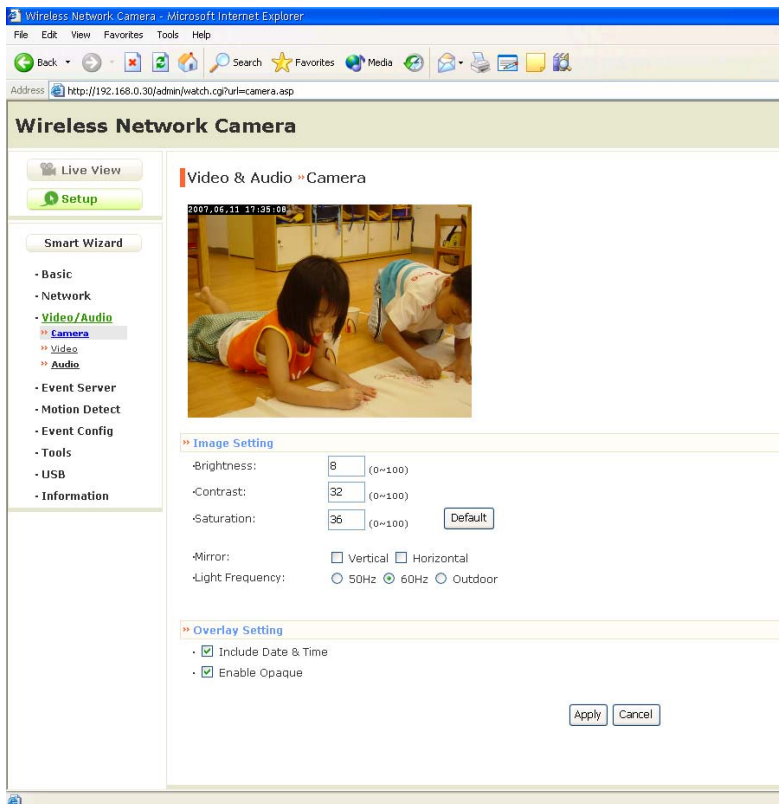

The screenshot shows a web browser window titled "Wireless Network Camera - Microsoft Internet Explorer". The address bar shows the URL "http://192.168.0.30/admin/watch.cgi?url=camera.asp". The page content is as follows:

- Wireless Network Camera** (Page Title)
- Navigation Buttons:** Live View, Setup, Smart Wizard.
- Smart Wizard Menu:**
 - Basic
 - Network
 - Video/Audio
 - » Camera (Selected)
 - » Video
 - » Audio
 - Event Server
 - Motion Detect
 - Event Config
 - Tools
 - USB
 - Information
- Video & Audio » Camera** (Section Header)
- Live View:** A video feed showing two children sitting on a wooden floor, looking at a large sheet of paper. The timestamp "2007.06.11 17:08:08" is visible in the top left corner of the video frame.
- Image Setting:**
 - Brightness: (0-100)
 - Contrast: (0-100)
 - Saturation: (0-100)
 - Mirror: Vertical Horizontal
 - Light Frequency: 50Hz 60Hz Outdoor
- Overlay Setting:**
 - Include Date & Time
 - Enable Opaque
- Buttons:**

Video & Audio >> Camera

■ Image Setting

- **Brightness:** Adjust the brightness level from 0 ~ 100.
- **Contrast:** Adjust the contrast level from 0 ~ 100.
- **Saturation:** Adjust the colors level from 0 ~ 100.

Click **Default** to restore the default settings of the three options above.

- **Mirror:** Select the **Horizontal** option to mirror the image horizontally. Select the **Vertical** option to mirror the image vertically.
- **Light Frequency:** Select the proper frequency according to the camera's location: **50Hz**, **60Hz**, or **Outdoor**.

■ Overlay Setting

- **Includes Date & Time:** Select this option to display the date & time stamp on the live view image.
- **Enable Opaque:** Select this option to set a black background to the displayed date & time stamp.

Video & Audio >> Video

■ MPEG4

- **Video Resolution:** Select the desired video resolution from the three formats: **VGA**, **QVGA** and **QQVGA**. The higher setting (VGA)

obtains better video quality while it uses more resource within your network.

- **Video Quality:** Select the desired image quality from five levels: **Lowest, Low, Medium, High, and Highest.**
- **Frame Rate:** Select **Auto** or a proper setting depending on your network status.

-

■ MJPEG

- **Video Resolution:** Select the desired video resolution from the three formats: **VGA, QVGA** and **QQVGA**. The higher setting (VGA) obtains better video quality while it uses more resource within your network.
- **Video Quality:** Select the desired image quality from five levels: **Lowest, Low, Medium, High, and Highest.**
- **Frame Rate:** Select **Auto** or a proper setting depending on your network status.

NOTE The camera supports both MPEG4 and MJPEG compression. MJPEG capture the images in JPEG format, which require higher bandwidth to view smooth video. The administrator can control the bandwidth of each connection well through the setting options above.

■ 3GPP

The camera supports 3GPP specification. Select the **Disable** option to disable this feature. Otherwise, select **3GPP Without Audio** or **3GPP With Audio** to transfer the video clips without or with audio.

If you use a mobile phone that supports 3GPP, you can also view the real-time streaming image captured by the camera on your phone (with the default player on the phone) by entering the RTSP link: [rtsp://\(IP address of the camera\)/3gp](rtsp://(IP address of the camera)/3gp).

Video & Audio >> Audio

■ Camera Microphone In

Select the **Enable** option to enable the camera's audio function, so that you can receive the on-site sound and voice from the camera.

■ Camera Speaker Out

This option is displayed when you connect a 2-way audio camera. Select the **Enable** option to enable the camera's external speaker function, so that the connected speaker can play the sound and voice through the camera.

- **Volume:** Set the speaker's volume.

4.6 Event Server Configuration

The Event Server menu contains three sub-menus that allow you to upload images to FTP, send emails that include still images, and store the images to a NAS system.

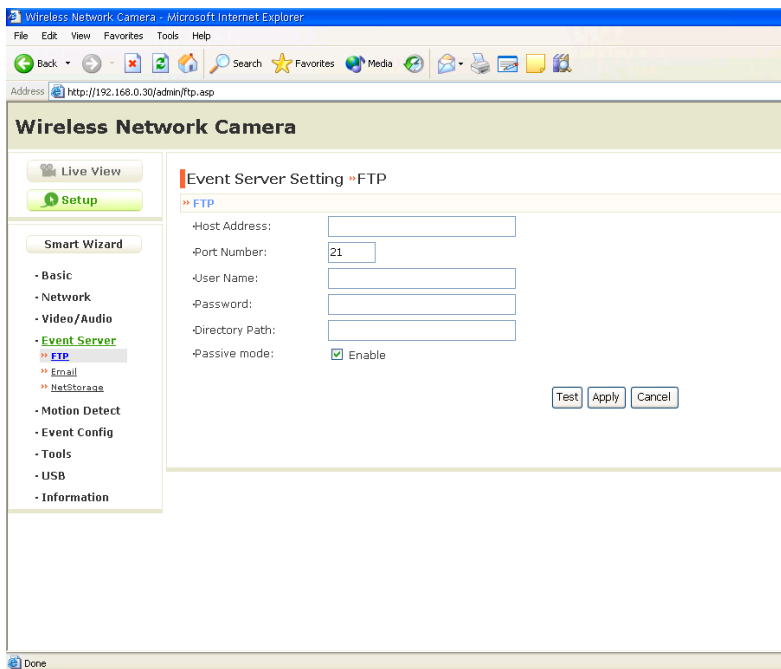

When you complete the required settings for FTP, Email, or Network Storage, click **Test** to test the related configuration is correct or not. Once the camera connects to the server successfully, click **Apply**.

Event Server Setting>> FTP

■ FTP

- **Host Address:** Enter the IP address of the target FTP server.
- **Port Number:** Enter the port number used for the FTP server.
- **User Name:** Enter the user name to login into the FTP server.
- **Password:** Enter the password to login into the FTP server.
- **Directory Path:** Enter the destination folder for uploading the images. For example, */Test/*.
- **Passive Mode:** Select the **Enable** option to enable passive mode.

Event Server Setting >> Email

■ Email

- **SMTP Server Address:** Enter the mail server address. For example, *mymail.com*.
- **Sender Email Address:** Enter the email address of the user who will send the email. For example, *John@mymail.com*.
- **Sender User Name:** Enter the user name to login the mail server.
- **Sender Password:** Enter the password to login the mail server.
- **Receiver #1 Email Address:** Enter the first email address of the user who will receive the email.
- **Receiver #2 Email Address:** Enter the second email address of the user who will receive the email.

Event Server Setting >> Network Storage

■ Net Storage

- **Samba Server Address:** Enter the IP address of the Network Storage server.
- **Share:** Assign the folder on the Network Storage server to share the files to users.
- **Path:** Assign the path for uploading the files on the Network Storage server. For example, */Test/*.
- **User Name:** Enter the user name to login into the Network Storage server.
- **Password:** Enter the password to login into the Network Storage server.
- **Split By:** When the file is too large to upload smoothly, use this option to split it by selecting **File Size** or **Recording Time**.
- **When Disk Full:** Select **Stop Recording** or **Recycle – Delete Oldest Folder of File** when the storage space on the Network Storage server is full.

NOTE The video recorded files in Network Storage are enclosed by AVI format without Audio.

4.7 Motion Detect

The Motion Detect menu contains the command and option that allow you to enable and set up the motion detection feature of the camera. The camera provides two detecting areas.

To enable the detecting area, select **Window 1** or **2** from the pull-down list, and then select **Enable**. When the detecting area is enabled, you can use the mouse to move the detecting area and change the area coverage.

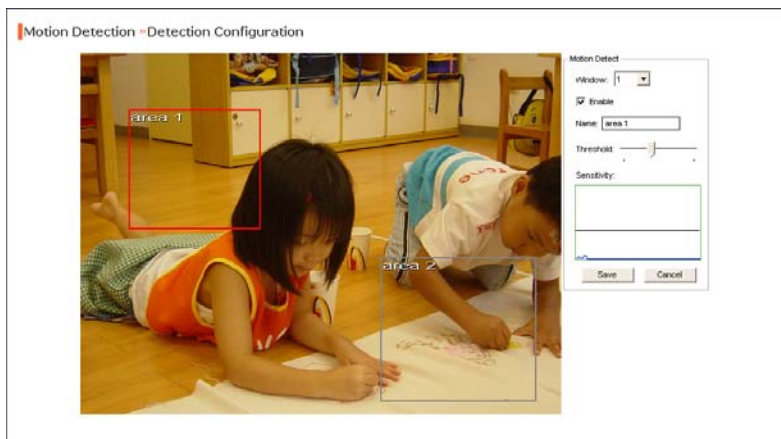

- **Name:** Assign a name to the detecting area.
- **Threshold:** Move the slide bar to adjust the level for detecting motion to record video.

4.8 Event Config

The Event Config menu contains four sub-menus that provide the commands to configure event profiles.

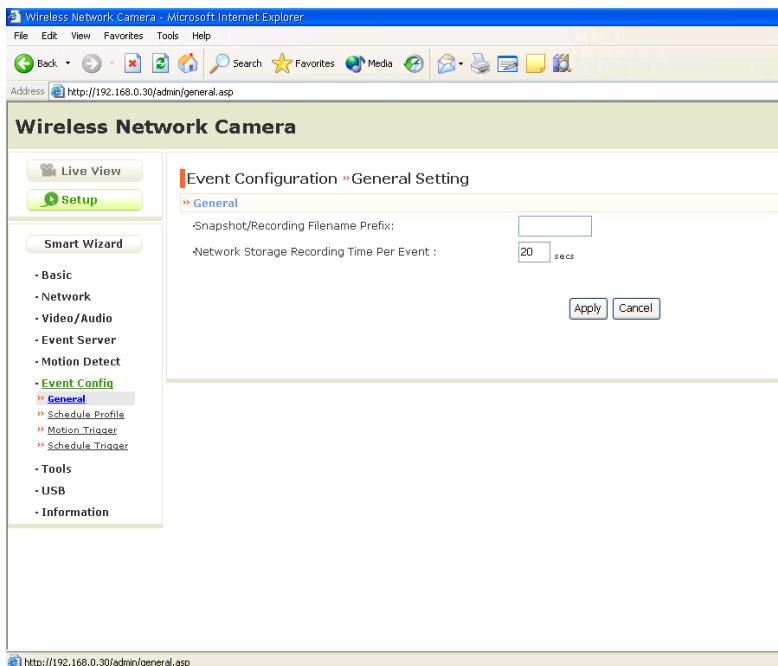

Event Configuration >> General Setting

- **Snapshot/Recording Filename Prefix:** You can assign a given prefix to each new captured file. Otherwise, leave this option blank to use the default setting.
- **Network Storage Recording Time Per Event:** Limit the recording time while you are using the Network Storage solution.

Event Configuration >> Arrange Schedule Profile

This sub-menu displays the scheduled profile(s). To customize the profile, click **Add** and then enter a descriptive name for the profile in the prompt dialog window. After entering the profile name, click **OK** and the profile is added to the Schedule Profiles list. To delete the profile, select the profile in the list and click **Delete**.

The screenshot shows the 'Event Configuration - Arrange Schedule Profile' window. At the top, there is a 'Schedule Profiles' list with one entry, 'classroom1'. To the right of this list are 'Add' and 'Delete' buttons. Below the list, the 'Profile Name' is set to 'classroom1'. The 'Weekdays' section has radio buttons for Sun, Mon, Tue, Wed, Thu, Fri, and Sat. Mon, Tue, and Wed are selected and highlighted in green. The 'Time List' section contains two entries: '09:00 - 12:00' and '13:00 - 17:00'. Below the time list are buttons for 'Add', 'Delete', 'Add this to all weekdays', and 'Delete this from all weekdays'. The 'Start Time' is set to 13:00 and the 'End Time' is set to 17:00. A 'Save' button is located at the bottom of the window.

- **Profile Name:** Display the profile name that you select in the Schedule Profiles list.
- **Weekdays:** Select the weekday(s) that you want to separately assign in the schedule profile. The weekday that has been assigned will be displayed with green color.
- **Time List:** Display the time period that you have assigned within the selected weekday. To assign the same time period to every weekday, click **Add this to all weekdays**; click **Delete this from all weekdays** to remove the selected time period from every weekday. Click Delete to remove the selected time period.
- **Start/End Time:** Enter the start and end time and then click **Add** to assign a time period within in the selected weekday.

Event Configuration >> Motion Detect Trigger

Select the **Enable** option to enable the trigger function of the camera, so that you can send captured images within the detecting area to the FTP server, email receiver, Network Storage server, or the connected USB device. You have to configure corresponding settings, such as FTP server and email server, to enable this feature.

- **Schedule Profile:** Select a schedule profile from the pull-down list.
- **Action:** Select the destination that the captured images will be sent to: **Send Email, FTP Upload, Record to Network Storage, or Save Image to USB.**

Event Configuration >> Schedule Trigger

You can separately configure the schedule for trigger function of the camera by **Email, FTP, or Network Storage**. Select the **Enable** option on each item, and then select a **Schedule Profile** from the pull-down list and set the **Interval** time.

NOTE If the setting value of the **Network Storage Recording Time Per Event** option in General Setting is longer than the **Interval** time in Network Storage Schedule, the recorded file will be a continuous video clip.

For example, if you set the **Network Storage Recording Time Per Event** as 10 seconds and the **Interval** as 5 seconds, recorded file becomes a non-stop video clip because the camera will record a 10-second video clip every 5 seconds.

4.9 Tools

The Tools menu provides the commands that allow you to restart or reset the camera. You can also backup and restore your configuration, and upgrade the firmware for the camera.

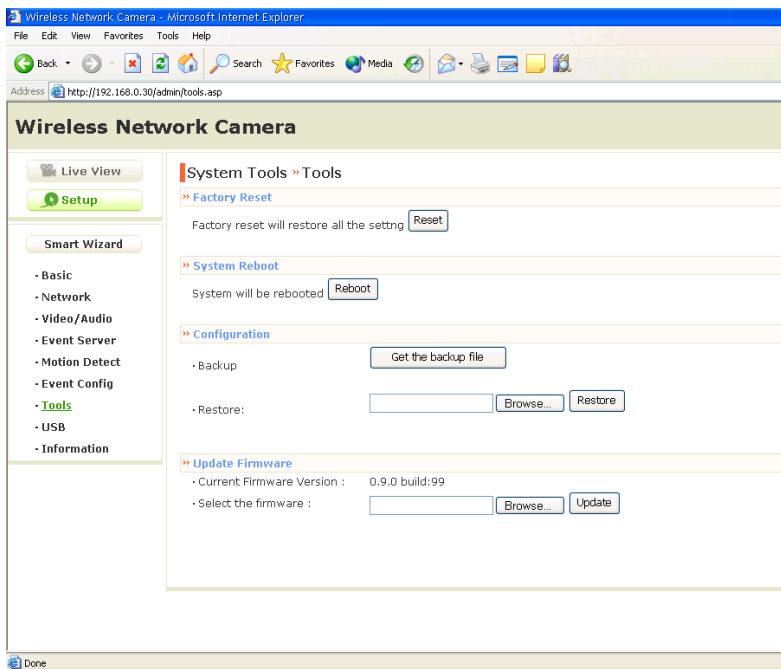

The screenshot shows a web browser window titled "Wireless Network Camera - Microsoft Internet Explorer". The address bar shows "http://192.168.0.30/admin/tools.asp". The page content is titled "Wireless Network Camera" and features a left-hand navigation menu with the following items: Live View, Setup, Smart Wizard, Basic, Network, Video/Audio, Event Server, Motion Detect, Event Config, Tools (highlighted in green), USB, and Information. The main content area is titled "System Tools » Tools" and contains four sections:

- Factory Reset**: "Factory reset will restore all the setting" with a "Reset" button.
- System Reboot**: "System will be rebooted" with a "Reboot" button.
- Configuration**: Includes a "Get the backup file" button, a "Backup" section, and a "Restore:" section with a text input field, a "Browse..." button, and a "Restore" button.
- Update Firmware**: Shows "Current Firmware Version : 0.9.0 build:99" and a "Select the firmware :" section with a text input field, a "Browse..." button, and an "Update" button.

The browser status bar at the bottom shows "Done".

■ **Factory Reset**

Click **Reset** to restore all factory default settings for the camera.

■ **System Reboot**

Click **Reboot** to restart the camera just like turning the device off and on. The camera configuration will be retained after rebooting.

■ **Configuration**

You can save your camera configuration as a backup file on your computer. Whenever you want to resume the original settings, you can restore them by retrieving the backup file.

- **Backup:** Click **Get the backup file** to save the current configuration of the camera.
- **Restore:** Click **Browse** to locate the backup file and then click **Restore**.

■ **Update Firmware**

This item displays the current firmware version. You can upgrade the firmware for your camera once you obtained a latest version of firmware.

- **Select the firmware:** Click **Browse** to locate the backup file and then click **Update**.

NOTE Make sure to keep the camera connected to the power source during the process of upgrading firmware. Otherwise, the camera might be damaged because of failure of upgrading firmware.

4.10 USB

The USB menu provides the information and controls of the connected USB device.

The screenshot shows a web browser window titled "Wireless Network Camera - Microsoft Internet Explorer" with the address bar displaying "http://192.168.0.30/admin/usb.asp". The page content is as follows:

- Wireless Network Camera** (Page Header)
- Navigation:** Live View, Setup, Smart Wizard.
- Smart Wizard:** Basic, Network, Video/Audio, Event Server, Motion Detect, Event Config, Tools, **USB**, Information.
- USB > USB setting** (Main Section)
 - USB Dismount**
 - Safely dismount USB:
 - USB Information**
 - Total space: Usb not available
 - Free space: Usb not available
 - USB Setting**
 - When Disk Full:
 - Stop Recording
 - Recycle - Delete Oldest Folder
- Buttons:** Apply, Cancel

■ **USB Dismount**

To safely remove the connected USB device, you can press the Unmount button for four seconds on the camera or click **Dismount** from this item.

■ **USB Information**

Display the **Total space** and **Free space** of the USB device.

■ **USB Setting**

- **When Disk Full:** Select **Stop Recording** or **Recycle – Delete Oldest Folder of File** when the storage space on the USB device is full.

NOTE The connected USB storage device can be only used to store still images.

4.11 Information

The Information menu displays the current configuration and events log of the camera.

The screenshot shows a web browser window titled "Wireless Network Camera - Microsoft Internet Explorer". The address bar shows "http://192.168.0.30/admin/info.asp". The page content is titled "Wireless Network Camera". On the left, there is a "Smart Wizard" menu with options: Live View, Setup, Basic, Network, Video/Audio, Event Server, Motion Detect, Event Config, Tools, USB, Information (highlighted), Device Info, and System Log. The main content area shows "System Information" with a sub-tab for "Device Information". It lists configuration details for Basic, Video & Audio, Network, and Wireless sections.

Section	Parameter	Value
Basic	Camera Name:	wireless network camera 1
	Location:	classroom 1
	Firmware Version:	0.9.0 build: 99
Video & Audio	MPEG4 Resolution:	VGA
	MJPEG Resolution:	VGA
	3GPP Enable :	Disable
	Microphone In	Enable
	Speaker Out	Enable
Network	IP Mode:	DHCP
	IP Address:	192.168.0.30
	Subnet Mask:	255.255.255.0
	Default Gateway:	192.168.0.1
	MAC Address:	00:FF:00:05:21:01
	Primary DNS Address:	
	Secondary DNS Address:	
	UPnP Enable :	Enable
	HTTP Port:	80
	RTSP Port:	554
Wireless	Connection:	Infrastructure
	Channel:	6
	Authentication :	Open
	Encryption :	None

■ **Device Info-** Display the Basic, Video & Audio, Network, and Wireless settings of the camera.

■ **System Log-** The Logs table displays the events log recorded by the system.

CHAPTER 5

APPENDIX

A.1 Specification

■ Image Sensor

Sensor	1/4" Colour CMOS
Resolution	640x480

■ Video

Compression	MPEG4/MJPEG/RTSP
Video resolution	VGA/QVGA/QQVGA; 30fps max.

■ System Hardware

Processor	ARM9 base
RAM	16MB SDRAM
ROM	4MB NOR Flash
Power	DC 5V

■ Communication

LAN	10/100Mbps Fast Ethernet, auto-sensed, Auto-MDIX
WLAN	IEEE 802.11b/g
Protocol support	TCP/IP, UDP, ICMP, DHCP, NTP, DNS, DDNS, SMTP, FTP, Samba, PPPoE, UPnP, RTP, RTSP, RTCP

- **User Interface**

LAN One RJ-45 port

Antenna One external antenna

Reset One Reset button

USB USB 1.1 port, with one unmount button;
Support FAT,FAT32 file system

Power distribution: 500mA Max.

LEDs Power LED (amber); Link LED (green)

- **Audio**

Input Built-in MIC

Output Headphone output jack (Mono)

Codec PCM/AMR (AMR is for 3GPP only)

- **Software**

OS Support Windows 2000/XP/Vista

Browser Internet Explorer 6.0 or above
Apple Safari 2 or above
Mozilla Firefox 2.00 or above

Software Xview Recording & Viewing Software
for playback/recording/configuration
features

- **Operating Environment**

Temperature - Operation: 5°C ~ 45°C
- Storage: -15°C ~ 60°C

Humidity - Operation: 20% ~ 85% non-condensing
- Storage: 0% ~ 90% non-condensing

■ EMI

FCC Class B, CE Class B

A.2 Glossary of Terms

NUMBERS

10BASE-T

10BASE-T is Ethernet over UTP Category III, IV, or V unshielded twisted-pair media.

100BASE-TX

The two-pair twisted-media implementation of 100BASE-T is called 100BASE-TX.

A

ADPCM

Adaptive Differential Pulse Code Modulation, a new technology improved from PCM, which encodes analog sounds to digital form.

AMR

AMR (Adaptive Multi-Rate) is an audio data compression scheme optimized for speech coding, which is adopted as the standard speech codec by 3GPP.

Applet

Applets are small Java programs that can be embedded in an HTML page. The rule at the moment is that an applet can only make an Internet connection to the computer from that the applet was sent.

ASCII

American Standard Code For Information Interchange, it is the standard method for encoding characters as 8-bit sequences of binary numbers, allowing a maximum of 256 characters.

ARP

Address Resolution Protocol. ARP is a protocol that resides at the TCP/IP Internet layer that delivers data on the same network by translating an IP address to a physical address.

AVI

Audio Video Interleave, it is a Windows platform audio and video file type, a common format for small movies and videos.

B

BOOTP

Bootstrap Protocol is an Internet protocol that can automatically configure a network device in a diskless workstation to give its own IP address.

C

Communication

Communication has four components: sender, receiver, message, and medium. In networks, devices and application tasks and processes communicate messages to each other over media. They represent the sender and receivers. The data they send is the message. The cabling or transmission method they use is the medium.

Connection

In networking, two devices establish a connection to communicate with each other.

D

DHCP

Developed by Microsoft, DHCP (Dynamic Host Configuration Protocol) is a protocol for assigning dynamic IP addresses to devices on a network. With dynamic addressing, a device can have a different IP address every time it connects to the network. In some systems, the device's IP address can even change while it is still connected. It also supports a mix of static and dynamic IP addresses. This simplifies the task for network administrators because the software keeps track of IP addresses rather than requiring an administrator to manage the task. A new computer can be added to a network without the hassle of manually assigning it a unique IP address. DHCP allows the specification for the service provided by a router, gateway, or other network device that automatically assigns an IP address to any device that requests one.

DNS

Domain Name System is an Internet service that translates domain names into IP addresses. Since domain names are alphabetic, they're easier to remember. The Internet however, is really based on IP addresses every time you use a domain name the DNS will translate the name into the corresponding IP address. For example, the domain name

www.network_camera.com might translate to *192.167.222.8*.

E

Enterprise network

An enterprise network consists of collections of networks connected to each other over a geographically dispersed area. The enterprise network serves the needs of a widely distributed company and operates the company's mission-critical applications.

Ethernet

The most popular LAN communication technology. There are a variety of types of Ethernet, including 10Mbps (traditional Ethernet), 100Mbps (Fast Ethernet), and 1,000Mbps (Gigabit Ethernet). Most Ethernet networks use Category 5 cabling to carry information, in the form of electrical signals, between devices. Ethernet is an implementation of CSMA/CD that operates in a bus or star topology.

F

Fast Ethernet

Fast Ethernet, also called 100BASE-T, operates at 10 or 100Mbps per second over UTP, STP, or fiber-optic media.

Firewall

Firewall is considered the first line of defense in protecting private information. For better security, data can be encrypted. A system designed to prevent unauthorized access to or from a private network. Firewalls are frequently used to prevent unauthorized Internet users from accessing private networks connected to the Internet, especially Intranets all messages entering or leaving the intranet pass through the firewall, which examines each message and blocks those that do not meet the specified security criteria.

G

Gateway

A gateway links computers that use different data formats together.

Group

Groups consist of several user machines that have similar

characteristics such as being in the same department.

H

HEX

Short for hexadecimal refers to the base-16 number system, which consists of 16 unique symbols: the numbers 0 to 9 and the letters A to F. For example, the decimal number 15 is represented as F in the hexadecimal numbering system. The hexadecimal system is useful because it can represent every byte (8 bits) as two consecutive hexadecimal digits. It is easier for humans to read hexadecimal numbers than binary numbers.

I

Intranet

This is a private network, inside an organization or company that uses the same software you will find on the public Internet. The only difference is that an Intranet is used for internal usage only.

Internet

The Internet is a globally linked system of computers that are logically connected based on the Internet Protocol (IP). The Internet provides different ways to access private and public information worldwide.

Internet address

To participate in Internet communications and on Internet Protocol-based networks, a node must have an Internet address that identifies it to the other nodes. All Internet addresses are IP addresses

IP

Internet Protocol is the standard that describes the layout of the basic unit of information on the Internet (the *packet*) and also details the numerical addressing format used to route the information. Your Internet service provider controls the IP address of any device it connects to the Internet. The IP addresses in your network must conform to IP addressing rules. In smaller LANs, most people will allow the DHCP function of a router or gateway to assign the IP addresses on internal networks.

IP address

IP address is a 32-binary digit number that identifies each sender or receiver of information that is sent in packets

across the Internet. For example 80.80.80.69 is an IP address. When you “call” that number, using any connection methods, you get connected to the computer that “owns” that IP address.

ISP

ISP (Internet Service Provider) is a company that maintains a network that is linked to the Internet by way of a dedicated communication line. An ISP offers the use of its dedicated communication lines to companies or individuals who can't afford the high monthly cost for a direct connection.

J

JAVA

Java is a programming language that is specially designed for writing programs that can be safely downloaded to your computer through the Internet without the fear of viruses. It is an object-oriented multi-thread programming best for creating applets and applications for the Internet, Intranet and other complex, distributed network.

L

LAN

Local Area Network a computer network that spans a relatively small area sharing common resources. Most LANs are confined to a single building or group of buildings.

M

MJPEG

MJPEG (Motion JPEG) composes a moving image by storing each frame of a moving picture sequence in JPEG compression, and then decompressing and displaying each frame at rapid speed to show the moving picture.

MPEG4

MPEG4 is designed to enable transmission and reception of high-quality audio and video over the Internet and next-generation mobile telephones.

N

NAT

Network Address Translator generally applied by a router that makes many different IP addresses on an internal network appear to the Internet as a single address. For routing messages properly within your network, each device requires a unique IP address. But the addresses may not be valid outside your network. NAT solves the problem. When devices within your network request information from the Internet, the requests are forwarded to the Internet under the router's IP address. NAT distributes the responses to the proper IP addresses within your network.

Network

A network consists of a collection of two or more devices, people, or components that communicate with each other over physical or virtual media. The most common types of network are:

LAN – (local area network): Computers are in close distance to one another. They are usually in the same office space, room, or building.

WAN – (wide area network): The computers are in different geographic locations and are connected by telephone lines or radio waves.

NWay Protocol

A network protocol that can automatically negotiate the highest possible transmission speed between two devices.

P

PCM

PCM (Pulse Code Modulation) is a technique for converting analog audio signals into digital form for transmission.

PING

Packet Internet Groper, a utility used to determine whether a specific IP address is accessible. It functions by sending a packet to the specified address and waits for a reply. It is primarily used to troubleshoot Internet connections.

PPPoE

Point-to-Point Protocol over Ethernet. PPPoE is a specification for connecting the users on an Ethernet to the Internet through a common broadband medium, such as

DSL or cable modem. All the users over the Ethernet share a common connection.

Protocol

Communication on the network is governed by sets of rules called protocols. Protocols provide the guidelines devices use to communicate with each other, and thus they have different functions. Some protocols are responsible for formatting and presenting and presenting data that will be transferred from file server memory to the file server's network adapter Others are responsible for filtering information between networks and forwarding data to its destination. Still other protocols dictate how data is transferred across the medium, and how servers respond to workstation requests and vice versa. Common network protocols responsible for the presentation and formatting of data for a network operating system are the Internetwork Packet Exchange (IPX) protocol or the Internet Protocol (IP). Protocols that dictate the format of data for transfers the medium include token-passing and Carrier Sense Multiple Access with Collision Detection (CSMA/CD), implemented as token-ring, ARCNET, FDDI, or Ethernet. The Router Information Protocol (RIP), a part of the Transmission Control Protocol/Internet Protocol (TCP/IP) suite, forwards packets from one network to another using the same network protocol.

R

RJ-45

RJ-45 connector is used for Ethernet cable connections.

Router

A router is the network software or hardware entity charged with routing packets between networks.

RTP

RTP (Real-time Transport Protocol) is a data transfer protocol defined to deliver **live media** to the clients at the same time, which defines the transmission of video and audio files in real time for Internet applications.

RTSP

RTSP (Real-time Streaming Protocol) is the standard used to transmit **stored media** to the client(s) at the same time, which provides client controls for random access to the content stream.

S

Server

It is a simple computer that provides resources, such as files or other information.

SIP

SIP (Session Initiated Protocol) is a standard protocol that delivers the real-time communication for Voice over IP (VoIP), which establishes sessions for features such as audio and video conferencing.

SMTP

The Simple Mail Transfer Protocol is used for Internet mail.

SNMP

Simple Network Management Protocol. SNMP was designed to provide a common foundation for managing network devices.

Station

In LANs, a station consists of a device that can communicate data on the network. In FDDI, a station includes both physical nodes and addressable logical devices. Workstations, single-attach stations, dual-attach stations, and concentrators are FDDI stations.

Subnet mask

In TCP/IP, the bits used to create the subnet are called the subnet mask.

T

(TCP/IP)

Transmission Control Protocol/Internet Protocol is a widely used transport protocol that connects diverse computers of various transmission methods. It was developed by the Department of Defense to connect different computer types and led to the development of the Internet.

Transceiver

A transceiver joins two network segments together. Transceivers can also be used to join a segment that uses one medium to a segment that uses a different medium. On a 10BASE-5 network, the transceiver connects the network adapter or other network device to the medium. Transceivers also can be used on 10BASE-2 or 10BASE-T networks to attach devices with AUI ports.

U

UDP

The User Datagram Protocol is a connectionless protocol that resides above IP in the TCP/IP suite

User Name

The USERNAME is the unique name assigned to each person who has access to the LAN.

Utility

It is a program that performs a specific task.

UTP

Unshielded twisted-pair. UTP is a form of cable used by all access methods. It consists of several pairs of wires enclosed in an unshielded sheath.

W

WAN

Wide-Area Network. A wide-area network consists of groups of interconnected computers that are separated by a wide distance and communicate with each other via common carrier telecommunication techniques.

WEP

WEP is widely used as the basic security protocol in Wi-Fi networks, which secures data transmissions using 64-bit or 128-bit encryption.

Windows

Windows is a graphical user interface for workstations that use DOS.

WPA

WPA (Wi-Fi Protected Access) is used to improve the security of Wi-Fi networks, replacing the current WEP standard. It uses its own encryption, Temporal Key Integrity Protocol (TKIP), to secure data during transmission.

WPA2

Wi-Fi Protected Access 2, the latest security specification that provides greater data protection and network access control for Wi-Fi networks. WPA2 uses the government-grade AES encryption algorithm and IEEE 802.1X-based authentication, which are required to secure large corporate networks.

OTHER MODELS

The following cameras are also available in the XIP3000 series:



Wired IP CCTV (Model: XIP3000)

- High Quality Images
- Real Time Streaming
- Low Light Mode
- Windows & Apple Compatible
- Motion Detection Alerts By Email
- Password Protected for extra security
- Free 16 Camera Recording and Viewing Software for Windows PCs included
- Weather Resistant (using optional housing, model: XIP3000H)



Wireless IP CCTV (Model: XIP3001)

- Wireless (802.11b/g) Network Compatible
- High Quality Images
- Real Time Streaming
- Low Light Mode
- Windows & Apple Compatible
- Motion Detection Alerts By Email
- Password Protected for extra security
- Free 16 Camera Recording and Viewing Software for Windows PCs included
- Weather Resistant (using optional housing, model: XIP3000H)

ACCESSORIES

These accessories allow you to expand XIP3000 series cameras into a complete system:



Weatherproof Housing and Wall Bracket (Model: XIP3000H)

Designed for use with XIP3000 series cameras, this housing allows the camera to be used externally.

- Specially designed for use with the XIP3000, XIP3001 and XIP3101 cameras.
- Heavy Duty durable design for extra protection
- Supplied complete with wall bracket



4 Camera IP Camera Recorder (NVR) (Model: XIP3000NVR)

Records video and audio from up to 4 Xvision XIP3000 series cameras on to its built in Hard Drives.

- Auto Finds cameras on the same Local Area Network
- Allows remote access from any compatible PC, allowing you to view all 4 cameras and playback recordings
- Saves having to use a PC to make recordings from your XIP3000 cameras
- Can be used with wired and wireless 802.11g networks
- Compatible with XIP3000, XIP3001 and XIP3101 cameras



4 Camera Wireless LCD Monitor (Model: XIP3000M)

7" Slimline LCD Monitor for viewing up to 4 XIP3000 series cameras.

- Auto finds cameras on the same Local Area Network
- Allows full screen viewing of each camera or Quad screen viewing of up to 4
- Saves having to use a PC to view IP cameras
- Can be used with wired and wireless 802.11g networks
- Compatible with XIP3000, XIP3001 and XIP3101 cameras

NOTES

TECHNICAL SUPPORT:

For Technical Support for any Xvision product please contact your local distributor.

LIMITED WARRANTY:

This product is supplied with a 1 Year warranty. The Warranty excludes products that have been misused, (including accidental damage) and damage caused by normal wear and tear. In the unlikely event that you encounter a problem with this product, it should be returned to the place of purchase.



Manufactured exclusively for:
Xvision (Europe) Group,
Head Office: London, U.K.
Email: info@x-vision.co.uk
Web: www.x-vision.co.uk